

WHITEPAPER

# Modernizing the RF Lab with Virtualization and Test Automation



▲ ACENTURY  
**LAMTA**

# Modernizing the RF Lab with Virtualization and Test Automation

There is a long-time customer of Acentury that is a Tier 1 wireless operator in a mature market. Their network environment includes many different technology vendors, multiple radio access technologies, and several frequency bands spanning 600 MHz to 3500 MHz. By any definition, it is a complex environment.

Subscriber growth is flat, and churn is a major driver of financial success. There is constant pressure to improve network performance, launch new technologies, and continuously deliver new and innovative services to attract and keep customers.

The typical wireless customer in this market is sophisticated. They understand quality of service, and how mobile phones are supposed to behave. They have high expectations of their service provider.

In response to these demands, this operator is careful to evaluate and certify various technologies and configurations before they are deployed into the

production network. One of their main tools for this is a large RF lab, and they turned to Acentury to help them solve various operational challenges

## Acentury LAMTA selected to automate the RF Lab

With so many radio sources, shield boxes and RF chambers to connect, using RF patch panels and separate variable attenuators became too cumbersome. The first step in modernizing the RF lab was to install RF switch matrices. These fully non-blocking RF switches allow any combination of RF signal inputs to be distributed to any combination of RF outputs, completely under software control. The Acentury LAMTA software platform was used to manage the configuration of the switch matrices and provides precise control over signal attenuation and routing.

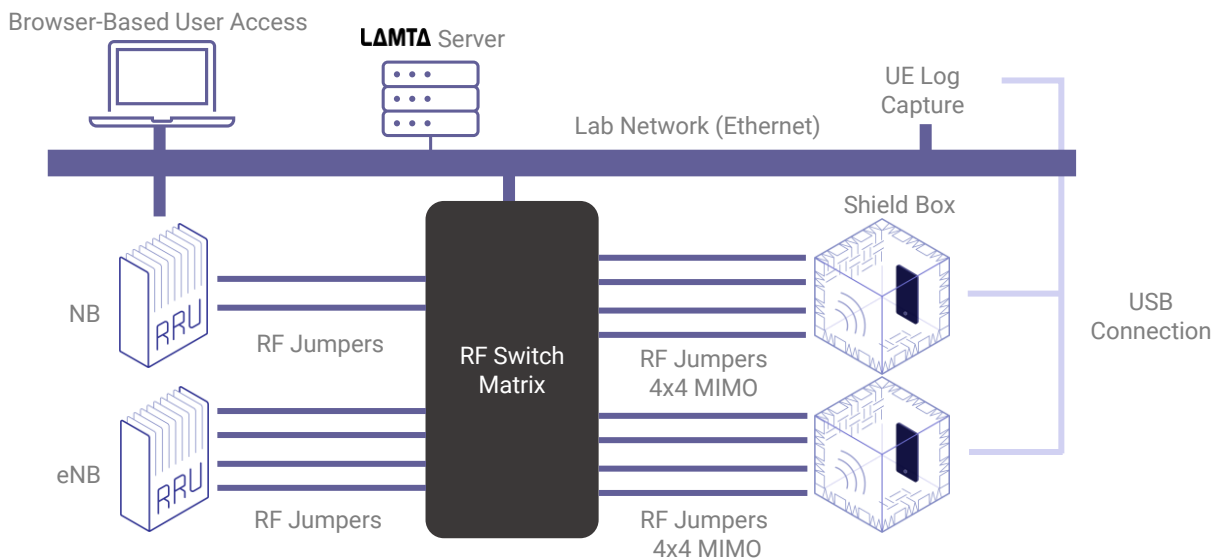

Chamber					Add	
Name	Description	Label	Status	Actions		
Chamber 1	6 AM to 6 PM	HandOver, Log Analysis, 5G	Active			
Chamber 2	6 PM to 6 AM	5G	Active			
Chamber 3	6 PM to 6 AM	5G, IoT	Active			
Chamber 4	6 AM to 6 PM	Log Analysis, LTE, 5G	Active			
Chamber 5	6 PM to 6 AM	VoLTE, VoNR, 5G	Active			
Chamber 6	6 AM to 6 PM	5G, Carrier Aggregation, HandOver, Log Analysis	Active			
Chamber 7	6 AM to 6 PM		Active			

## Increase RF lab efficiency with Acentury LAMTA

The first benefit to replacing RF patch panels with software-controlled switch matrices was a massive reduction in test set-up and tear-down times. The manual work hours of disconnecting and reconnecting RF patch cables to create different test scenarios are replaced with a few minutes of switch reconfiguration through the LAMTA software user interface. No more time is wasted tracing jumpers and signal paths, and the time savings can be reinvested in running better RF tests. Another side benefit was improving the usable life of expensive RF jumpers and connectors by significantly reducing the wear and tear of repeated connections and disconnections.

The mobile network operator (MNO) realized additional efficiency benefits now that RF sources can be used in

multiple tests simultaneously. Using the old setup with patch panels, the signal from an eNB, gNB or RRU can only be routed to one test chamber or shield box at a time. Using LAMTA, they can be fed to multiple chambers at once, and the signal entering each chamber can be controlled independently. This allows multiple testers to use the same RF source at the same time.

Further, LAMTA enabled this operator to configure test scripts and run them automatically without user involvement. This eliminated manual test runs managed by highly skilled lab technicians.

With Acentury LAMTA, their lab resources spend less time configuring, and more time testing. Highly skilled lab technicians also spent less time running manual-intensive tasks, and more time focused on higher-valued lab activities.

## Improve RF test repeatability with Acentury LAMTA

One of the operator's biggest issues was test repeatability. Using RF patch panels and manually controlling signal attenuation made it impossible to maintain a repeatable process from test to test, and eroded confidence with test results. Acentury LAMTA helped address this in several ways.

With LAMTA, the test environment never changes. Test engineers connected RF cables once and they never have to touch them again. Since connections are never altered after initial setup, this MNO was assured that the test environment is the same test after test.

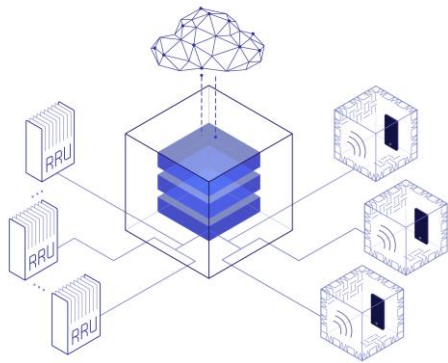

Test result variability was also previously caused by the overuse and wear and tear from RF jumpers and connectors. High-quality components will degrade after many connection and disconnection cycles, and the performance deterioration isn't obvious. Since LAMTA eliminates the need for manual reconfiguration, this was no longer a concern. The other side benefit is that they don't have to replace expensive RF cables when connectors wore out or shielding became damaged because of overuse.

The largest factor influencing test repeatability was the tester themselves. When the tester was responsible for manually controlling attenuation and rates of change, it was virtually impossible to effectively repeat a test.

Imagine trying to manually control variable attenuation for multiple base stations when simulating handover in a carrier aggregation scenario. With LAMTA, all attenuation is software controlled, ensuring a repeatable process from test to test.

Another benefit of software control is that tests can be repeated with automation. Testers are assured that each test will run the same and software-controlled attenuation ensures exactly the same test each time.

With Acentury LAMTA, tester engineers have complete confidence in their test results.

## Simulate complex RF scenarios using Acentury LAMTA

Wireless subscribers are becoming more demanding, so it is more important than ever to ensure robust network performance. As such, there is an ever-increasing need for testing sophisticated features in the lab before they are released in the production network.

Acentury's LAMTA solution addressed this challenge by enabling simulation of "real-world" situations in the lab. Software control over RF switch matrices allows the precise combination of many RF signals in controlled ways. In this way, network features and capabilities like handovers, roaming, carrier aggregation and MIMO can be thoroughly tested. They rely on LAMTA to evaluate new infrastructure software loads and configuration details before they are released into the live network.

This has some important benefits. The impact of new infrastructure software releases on overall network performance can be evaluated prior to field deployment. The behaviour of subscriber devices can also be measured, and comparisons can be made between various firmware releases. Since the testing is automated and repeatable, tests can be run the same way identically hundreds of times so the results will be statistically significant.

With Acentury LAMTA, they can perform more tests – more quickly – ensuring greater confidence in the performance of their network.

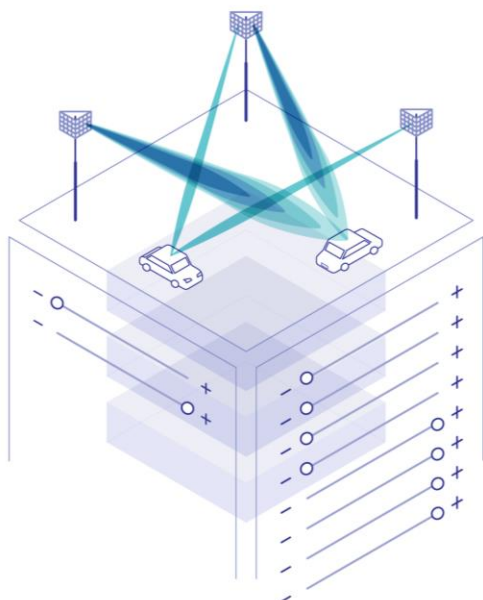

## Manage RF test resources using Acentury LAMTA

As RF labs get larger, it becomes even harder to manage all the resources efficiently and effectively. Lab managers need to co-ordinate the needs and objectives of many different testers with the availability of radio and chamber resources. The MNO found this challenge to be time-consuming and often frustrating work.

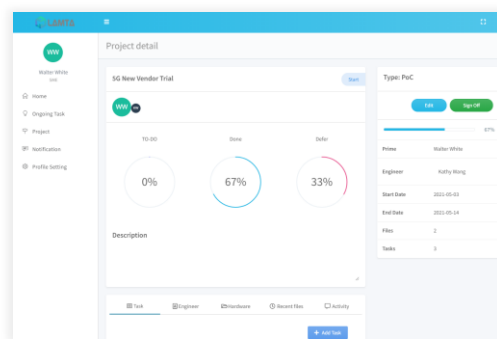

LAMTA offers a resource management solution. Using this module, lab managers can make certain resources available to different users. Individual users can see what resources are available and when, and book time on them directly.

LAMTA also provides a testing progress view. Lab managers can see which testing projects are on schedule, and which ones are ahead or behind. With this information, they can allocate resources more effectively across the organization.

With Acentury LAMTA, lab managers have a complete picture of how the RF lab is being used.

## Operate an RF Lab remotely with Acentury LAMTA

Perhaps the biggest benefit that this LAMTA customer experienced was the ability to operate the RF lab remotely. This became critically important during the COVID-19 pandemic. When their office spaces were closed for health and safety reasons, it was difficult or even impossible to conduct testing that required many people on-site in the RF lab.

LAMTA easily solved that problem. During COVID, this operator was able to have testers complete their work from home, with only a small number of people physically at the RF lab.

A lab equipped with LAMTA does not require any manual labour to reconfigure RF cabling between tests. All RF path switching and attenuation is automated through the software-controlled RF switch matrices and operated via the LAMTA user interface. Devices under test are monitored remotely. Testers can be anywhere with an Internet connection.

LAMTA can control equipment across multiple RF lab sites as well. In this way, testers in one city can use test resources (RF sources, chambers, etc.) located in another city, town or country. A single RF lab location could be used by testers around the globe, 24 hours a day.

## End-to-End Testing with Acentury LAMTA

In addition to controlling the RF path switching and attenuation, LAMTA can also control the rest of the test environment. It supports the option to control network elements such as NodeB radio units from several different equipment vendors. User equipment such as Android Smartphones can also be controlled through LAMTA. This allows test engineers to operate the RF test environment through a single interface.

## An RF Lab Automation Platform for Labs of All Sizes

Because of its modular nature, LAMTA is suitable for wireless operators of all sizes and levels of sophistication.

LAMTA supports RF switch matrices and variable attenuators of various sizes from different manufacturers. It can connect to any RF chamber type, from small desktop shielded enclosures to full-size walk-in Faraday cages and anechoic chambers.

The LAMTA software itself is modular and operators can simply select the modules they need. It is also available as a perpetual license or SaaS model which allows budget flexibility.

## Acentury LAMTA: the right tool for the job

When it came to automate their RF lab, this Tier 1 operator turned to Acentury. Since that decision, they have continued to expand their LAMTA deployment to control over a dozen RF switches, more than 10 RF chambers, three different RF infrastructure vendors and at least seven frequency bands with more on the horizon.

They count on LAMTA every day to help validate network configuration changes and handset software versions, ensuring that they perform up to their customer's expectations.

Acentury LAMTA is the end-to-end lab management solution for any RF lab. Contact [info@acentury.ca](mailto:info@acentury.ca) to learn how LAMTA can work for you.



Acentury Inc.

120 West Beaver Creek Road, Unit 13, Richmond Hill, ON L4B 1L2, Canada

+1-905-554-3633

Email: [info@acentury.ca](mailto:info@acentury.ca)

acentury.ca | October 2021